







INSTRUCTION MANUAL

RP: RACK & PINION PART TURN PNEUMATIC ACTUATOR

DOUBLE ACTING (DA) AND SPRING RETURN (SR)

RP10 - RP480

INDEX:

		Pag.
1.	GENERAL FEATURES	3
2.	WORKING CONDITIONS	3
3.	CONSTRUCTION FEATURES	6
4.	CODING SCHEME	7
5.	FUNCTIONNING	8
6.	SAFETY NOTICE	10
7.	INSTALLATION INSTRUCTION	10
8.	OPENING AND CLOSING ANGLE SETTING	14
9.	MATERIALS AND DURABILITY 	18
10.	MAINTENANCE 	21
11.	ATEX SPECIFICATIONS	29
12.	ACTUATORS SPECIAL VERSIONS	30
13.	STORAGE 	30
14.	TROUBLE SHOOTING	30
15.	DISPOSAL OF PRODUCTS AT THE END OF THEIR LIFE CYCLE 	31
16.	DECLARATION OF CONFORMITY	31
17.	ENVIRONMENT IMPACT 	31

 **Environmentally friendly:** under the green leaf icon you can find the instructions for a correct and environmentally friendly handling of the product.

RP-10 ÷ RP-240 (GAS)
 RP-10 ÷ RP-480 (NPT)

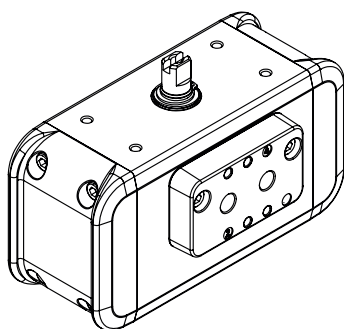

RP-300 ÷ RP-480 (GAS)

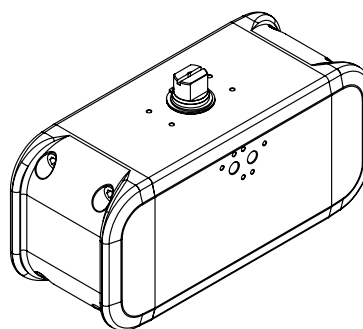

ACTUATECH reserves the right to change, at any time, features and data of its own products, to better improve their quality and lifetime.

FOREWORD

Present User's Installation and Maintenance Manual has been edited in conformity with:

- 2006/42/EC Directive "Machinery";
- 2014/34/UE Directive "Equipment and protection systems designated to be used in potentially explosive atmospheres" (ATEX);

Following standards/technical specifications also applied:

- EN 15714-3:2009 Industrial valves: Actuators – Pneumatic part-turn actuators for industrial valves;
- IEC 61508:2010-1/7 Functional safety of electrical/electronic/programmable electronic safety-related systems. Part 1÷7;
- UNI CEN/TS 764-6:2005 Pressure equipment Part 6: Operating instructions structure and contents;

1. GENERAL FEATURES

ACTUATECH manufactures a wide range of part-turn pneumatic actuators for valve remote control. Actuators are available on Double Acting (DA) and Spring Return (SR) versions.

Main actuator purpose is to open and close valves using an electric-pneumatic connection on remote control, without any manual operation (lever or hand wheel).

RP actuators use a Rack & Pinon kinetics to transform a rectilinear motion generated by pistons into a shaft rotational motion $0^{\circ}\pm 90^{\circ}$. Standard actuators (DA and SR) have a clockwise rotation (CW) direction to close the valves (0° closed valve, 90° opened valve), but counter-clockwise rotation (CCW) versions (0° opened valve, 90° closed valve) are available too.

Double acting (DA) Rack & Pinon actuators have a double constant rectilinear torque curve, while Spring Return (SR) Rack & Pinon actuators have a decreasing rectilinear torque curve.

The components for the actuator maintenance are supplied in the ACTUATECH spare part kit (see section 9 exploded views).

Actuators maintenance should be done by ACTUATECH or trained personnel only (see section 10).

This instruction manual contains important information regarding operation, installation, maintenance, and storage of ACTUATECH actuators. Please read it carefully before installation and keep it in a safe place for further reference.

Actuators are components without defined and proper functionality.

Below you will find the safety instructions, minimum information for storage / ware cylinder, installation, commissioning, maintenance as well as instructions for products disposal at the end of their life cycle.

ACTUATECH disclaims any liability for damage caused by improper use, even if partial, respect to the information contained in this manual.

2. WORKING CONDITIONS

2.1 Installation

Standard ACTUATECH actuators are suitable for indoor and outdoor installation. Degrees of protection provided by enclosures according to IEC 60529 - IP rating 66/67/68. Technical features such as type, size, operating pressure, output torque, operating temperature, flange connection, product code and production date are readable directly on the product by a printed or a laser-graving label (see section 3).

2.2 Operating medium

Use filtered compressed air not necessarily lubricated according to UNI EN 15714-3:2009 or inert gases compatible with internal actuator parts and lubricants. Operating medium must have a dew point equal to -20°C (-4°F) or, at least, 10°C (50°F) below the ambient temperature (ISO 8573-1, Class 3). Maximum particle size must not exceed $40\ \mu\text{m}$ (ISO 8573-1, Class 5).

2.3 Supply operating pressure

Nominal supply pressure 5,5 bar (80 PSI) for Double Acting, 6 bar (87 PSI) for Spring Return RS60. Maximum supply pressure 8 bar (116 PSI).

2.4 Operating temperature

Standard working temperature range from -20°C (-4°F) to 80°C (176°F).

Actuators for Low or High temperature applications are available, please contact us.

Supplementary protection (e.g. screens, sheds, or integral painting) are strictly recommended for high humidity and low temperature application.

2.5 Operating drive rotation

Part turn actuator rotation angle is nominally 90° with a $\pm 5^{\circ}$ adjusting stroke: closing setting from -5° to $+5^{\circ}$ and opening setting from 85° to 95° .

2.6 Cycle time

Cycle time depends on different operational and installation factors such as supply pressure, flow capacity, pipe size connection, solenoid valve performance, valve torque and characteristics, ambient temperature condition.

Actuator opening, closing and open/close cycle times

Double Acting	0° - 90° cycle time (ms)	90° - 0° cycle time (ms)
RP10	23	21
RP20	73	47
RP40	131	110
RP60	160	120
RP80	189	130
RP120	137	125
RP160	183	177
RP240	304	288
RP300	383	354
RP480	522	455

Spring Return	0° - 90° cycle time (ms)	90° - 0° cycle time (ms)
RP20	79	60
RP40	155	170
RP60	188	178
RP80	221	187
RP120	220	207
RP160	273	236
RP240	330	342
RP300	559	509
RP480	697	772

Above timetable refers to a standard actuator working cycle at the following tests conditions:

Ambient temperature	18÷25°C (64,4÷77°F)
Supply pressure	compressed air; 5,5 bar (80 psi) for double acting and 6 bar (87psi) for spring return
Operating drive rotation	90° in both directions
Load	free

DA actuators operate with solenoid valves 5/2 ISO 1-2, while SR actuators operate with solenoid valves 3/2. Time tested by Electronic Timer device.

Note: different working conditions such as air pressure, piping connection, filters, or solenoid valves, could change operations timing.

2.7 Lubrication

Actuators are factory lubricated for standard life-working condition. During maintenance and reassembling, we recommend using, for standard version, TECNOLUBE SYNTHY POLYMER 402, or equivalents. For low and high temperature actuators contact us.

2.8 Internal wear protection

Cylinder inner part is lapped to obtain a fine roughness surface and it is protected by a 20µm technical oxidation layer. Pistons slide supports are in P.T.F.E. or polyurethane material only, no rubber is in contact to cylinder inner surface.

2.9 External protection

ACTUATECH standard actuators are suitable for indoor and outdoor installation. Aluminium cylinder has an external corrosion protection realized by a 20µm technical oxidation layer. Casted aluminium end caps are polyester painted. The nickel-plated transmission shaft. Grub screw and caps screws are in stainless steel. Actuators for aggressive or severe environment applications are available, please contact us.

2.10 Functional Safety

ACTUATECH pneumatic actuators are suitable for installations which require high level of functional reliability, up to SIL3, in compliance with the IEC 61508 Standard.

2.11 Marking and classification

Actuator body are impressed by laser marking or by an additional label (depending on the actuator model) as below indicated.

①	Manufacturer Name, Logo, Address	④	IC Symbol (SR type), fail to close, fail to open
②	Product code and technical features	⑤	Production date (yy/m)
③	ATEX Directive marking (see section 11)		

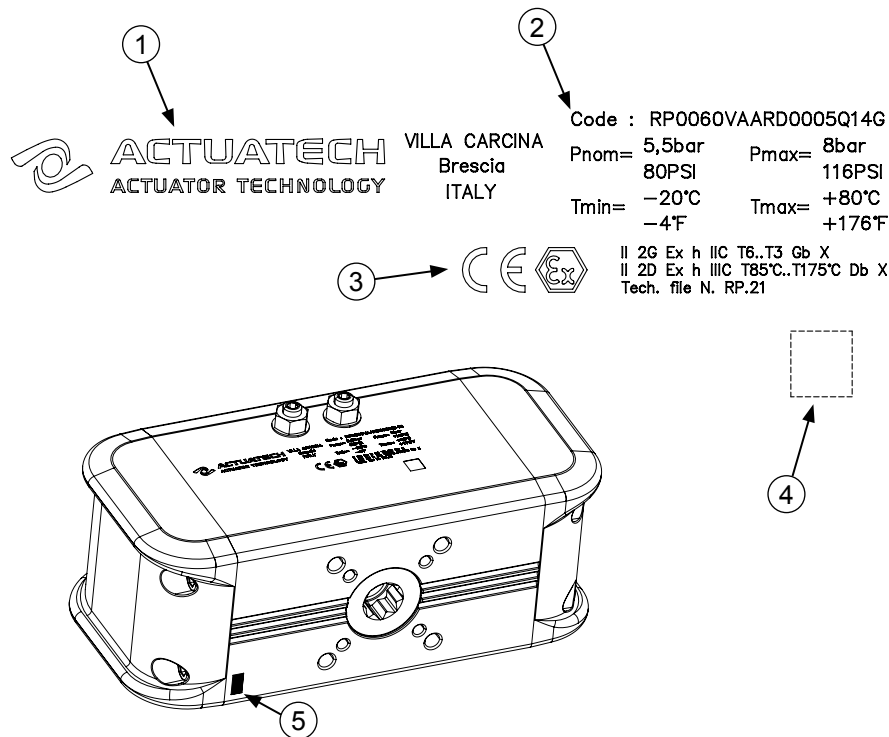

Low temperature version marking	T. min.= -50°C (-58°F)	T. max= +60°C (140°F)
High temperature version marking	T. min.= -20°C (-4°F)	T. max= 150°C (302°F)

3. CONSTRUCTION FEATURES

RP-10 ÷ RP-240 (GAS)
 RP-10 ÷ RP-480 (NPT)

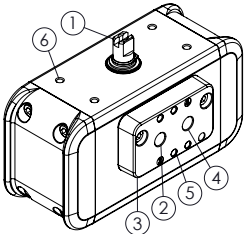

RP-300 ÷ RP-480 (GAS)

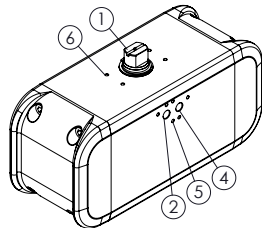

RP-10 ÷ RP-480

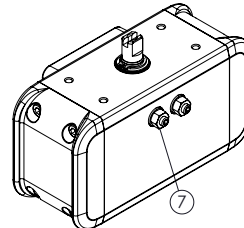

RP-10 ÷ RP-480

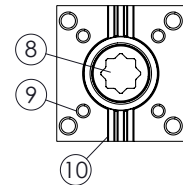

①	Shaft (shaft slot indicates valve position; image shows a totally open position)
②	Inner chamber supply hole: GAS or NPT threading
③	Namur plate, for standard versions: - GAS threading available from RP10 to RP240 (not available for RP300 and RP480); - NPT threading available from RP10 to RP480;
④	Outer chamber supply hole: GAS or NPT threading
⑤	VDI/VDE 3845 Namur threaded connection holes: - GAS threaded on the Namur plate from RP10 to RP240; - GAS threaded on the cylinder for RP300 and RP480; - NPT threaded on the cylinder from RP10 to RP480;
⑥	Threaded holes according to VDI/VDE 3845 to connect eventual accessories
⑦	Adjustment grub screw for closing and opening setting ($\pm 5^\circ$): - closing setting from -5° to $+5^\circ$; - opening setting from 85° to 95° ;
⑧	Bi-square Drive
⑨	Valve connection flange
⑩	Evacuation grooves (in case of shaft leakages)

Customizations available, see section 4 or ACTUATECH catalogue.

For specific applications is available a wide range of actuators accessories on ACTUATECH catalogue.

4. CODING SCHEME

AA	BBB	CC	D	E	F	GG	HH	I	JJ	K	L
Types meanings		Feature		Reference							
AA	Brand	RP	Rack&Pinion								
BBB	Size	0010									
		0020									
		0040									
		0060									
		0080									
		0120									
		0160									
		0240									
		0300									
		0480									
CC	Customer	VA	ACTUATECH								
D	Rotation Angle	A	90°								
		B*	180°								
		C*	120°								
		D*	135°								
E	Closing Direction	R	Clockwise rotation								
		L	Counter-clockwise rotation								
F	Operating Mode	S	Spring Return Fail Close								
		O	Spring Return Fail Open								
		D	Double effect								
GG	Springs used	00	No springs								
		20	2,0 bar springs								
		25	2,5 bar springs								
		30	3,0 bar springs								
		35	3,5 bar springs								
		40	4,0 bar springs								
		45	4,5 bar springs								
		50	5,0 bar springs								
		55	5,5 bar springs								
HH	Smaller Flange Type	03	F03								
		04	F04								
		05	F05								
		07	F07								
		10	F10								
		12	F12								
I	Lower shaft seat shape (socket)	Q	Star shaft								
		D*	Flat head shaft								
JJ	Lower shaft seat size (socket)	09	Shaft dimension 9mm								
		11	Shaft dimension 11mm								
		14	Shaft dimension 14mm								
		17	Shaft dimension 17mm								
		22	Shaft dimension 22mm								
		27	Shaft dimension 27mm								
		K	Air connection	G	Namur plate GAS						
N	Namur plate NPT										
0	Gas Thread on the cylinder (no Namur interface)										
I	Namur interface, integrated Gas threads										
L	Versions	-	Standard								
		6*	Low temperature								
		4*	High temperature								

Example

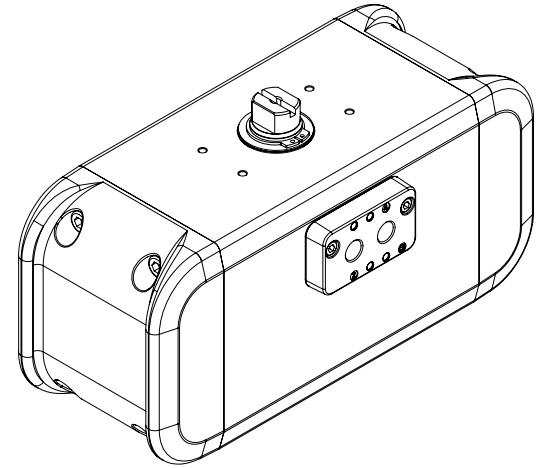

RP0160VAARS6007Q22G6

Types	Features
RP	Rack&Pinion
160	Model
VA	ACTUATECH
A	90° Rotation angle
R	Clockwise closing direction
S	Spring Return Fail Close
60	6,0 bar springs
07	F07 F10 flange
Q	Star shaft
22	22mm squared socket
G	NAMUR plate GAS
6	Low temperature Version

*Only on request.

N.B. For special versions contact ACTUATECH.

ACTUATECH S.p.A.

Via S. Lorenzo, 70, 25069 Villa Carcina (BS) Italy
 Ph. +39 030 8908142 · Fax +39 030 8908143 · actuatech@actuatech.com · www.actuatech.com

5. FUNCTIONING

Below described the main operating configuration. In case your product does not meet the following schemes, please look at ACTUATECH catalogue or contact us.

5.1 Double acting (DA) actuator

Supplying air into port (2) actuator shaft rotates counter-clockwise (CCW) to open the valve. Conversely, supplying air into port (4) actuator shaft rotates clockwise (CW) to close the valve.

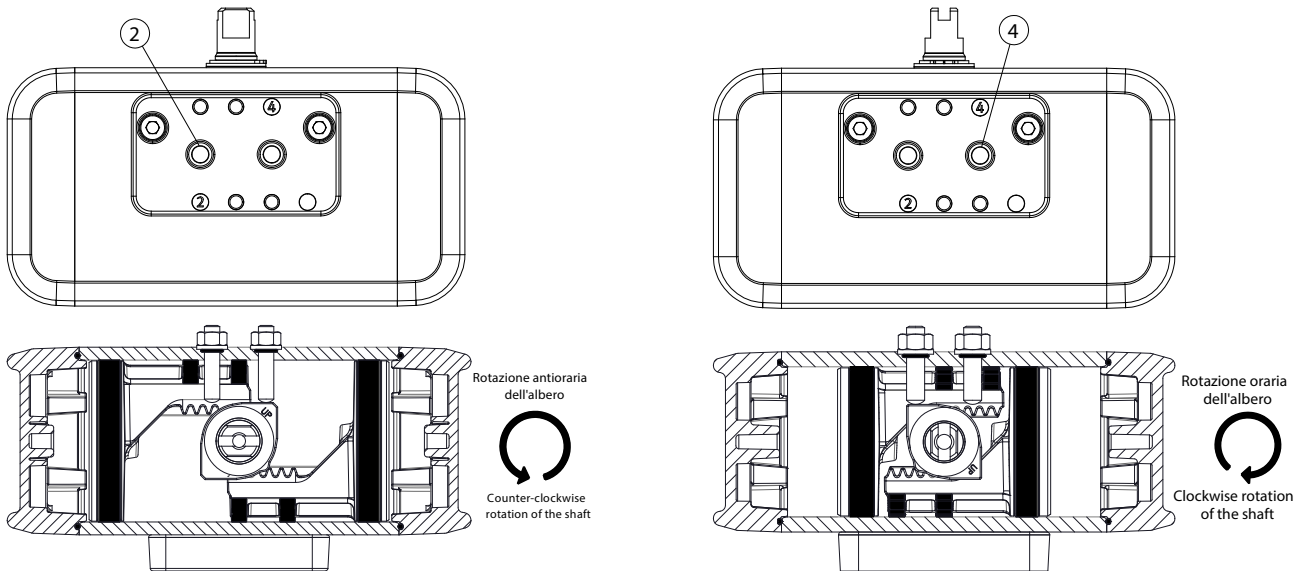

5.2 Spring Return (SR) FAIL TO CLOSE

Supplying air into port (2) pistons move outward compressing the springs and actuator shaft rotates counter-clockwise (CCW) to open the valve. Closing action is realized stopping air feeding. Springs energy push pistons back and consequently shaft rotates clockwise (CW).

To avoid dust or solid particles incoming, close port (4) using a cap. In case of explosive environment use protection caps in compliance with National safety/technical Standards or Regulations.

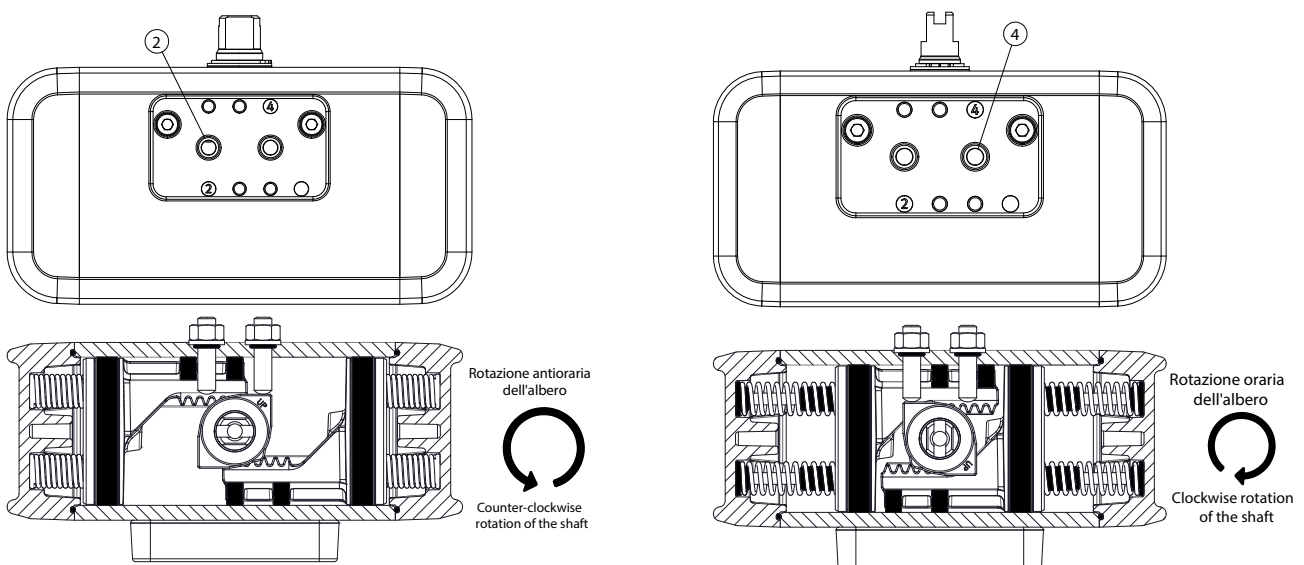

5.3 Spring Return (SR) FAIL TO OPEN

Supplying air into port (2) pistons move outward compressing the springs and actuator shaft rotates clockwise to close the valve. Opening action is realized stopping air feeding. Springs energy push pistons back and consequently shaft rotates counter-clockwise.

To avoid dust or solid particles incoming, close port (4) using a cap. In case of explosive environment use protection caps in compliance with National safety or technical Standards.

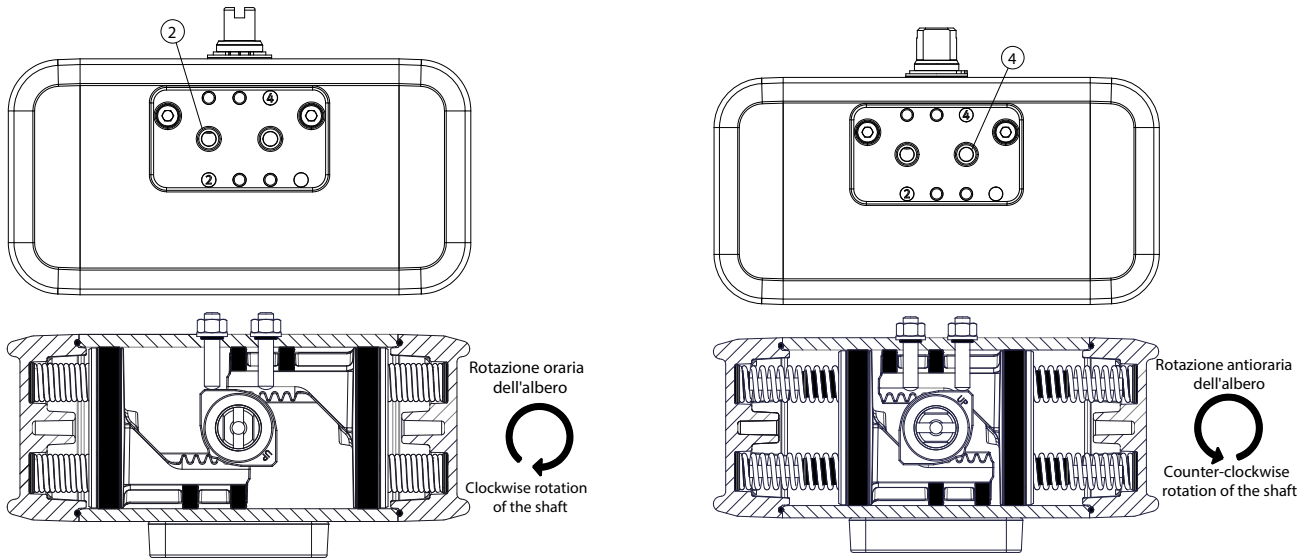

5.4 Connection diagram

Remote operation control should be done connecting a direct solenoid valve to VDE/VDI 3845 NAMUR plate or connecting a piping system directly to ports (2) (4). Use an independent electric control cabinet.

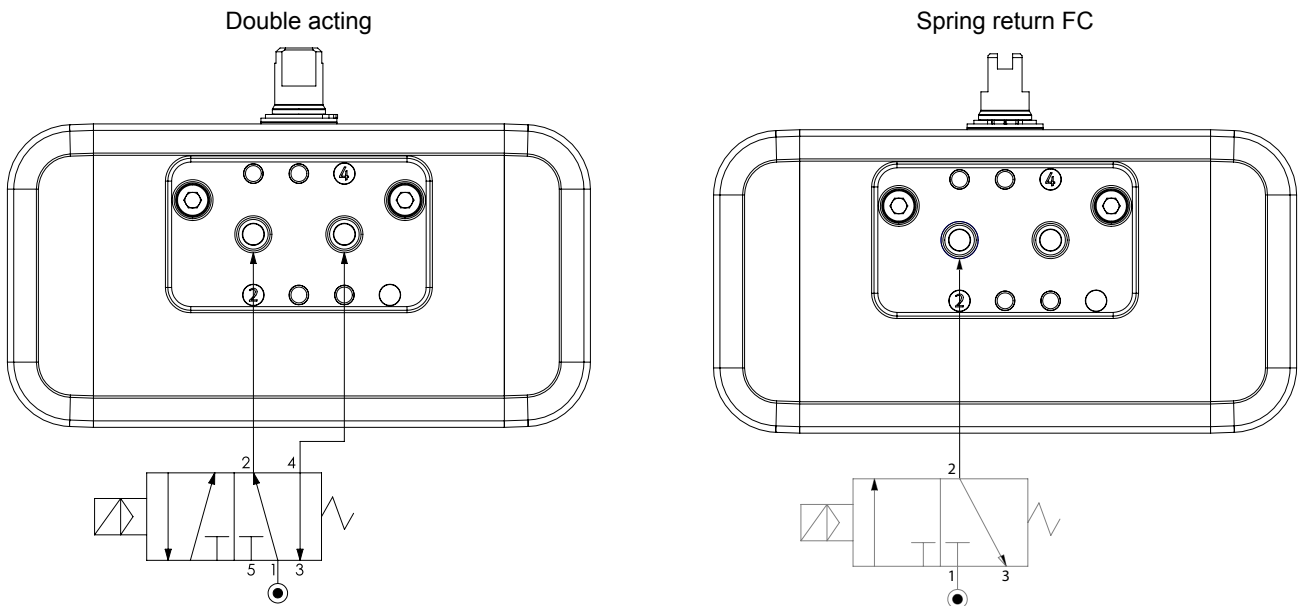

According with ISO 5599-2 Standard, actuator ports connection position, location, orientation and form shall be clearly identified and marked with numbers 2 and 4.

Standard Double Acting (DA) and Spring Return (SR) actuators shall be Clockwise (CW) direction for Closed valves, while Counter-Clockwise (CCW) direction for Opened valves.

6. SAFETY NOTICE

- ⚠ Actuator must be used within pressure limits only, submit it to overpressure will damage it;
- ⚠ Actuator must be used within temperature limits only, overstep temperature limits will damage it;
- ⚠ Operating actuator in corrosive environments without suitable and required external protection will damage it;
- ⚠ During installation, service or maintenance activities actuator must be pressure-less, disconnect air feeding and make sure that air ports have been completely vented;
- ⚠ Do not remove any component if actuator is still under pressure or installed in the line;
- ⚠ In case of a fall, actuators could generate serious injuries to operators, use suitable lifting equipment. Do not use air feeding holes to hang up the product;
- ⚠ Before connecting actuator and valve, make sure that valve rotation is according with actuator operating rotation and upper shaft slot orientation;
- ⚠ Before installing an actuated valve, carry out some cycling test to ensure correct connection and actuator/valve functionality;
- ⚠ Actuator installation shall be done in compliance with National safety/technical Standards or Regulations;
- ⚠ **ACTUATECH cannot be considered responsible for any damage to people, animals or things due to an improper use of the product.**

7. INSTALLATION INSTRUCTIONS

Before actuator installation check its conditions to verify eventually failure during transport and/or storage.

Actuator purpose is a remote control of a valve (opening and closing actions) avoiding manual operations. Actuator uses air or gas controlled by a mechanic, pneumatic or electropneumatic valve. Size actuator choice might be affected by system design, chemical/physical flow and environmental conditions, consequently higher safety factor can be required.

- Carefully read this instruction manual and the handbook included in the box.
- Take care of actuator features limit indicated on the labels to ensure the suitability.

Please verify actuator/valve conditions according to the above safety warnings and strictly follow the below indications.

- Check actuator position looking at shaft slot orientation;
- Double acting (DA) actuator is always supplied in opened position;
- Fail Close Spring Return (SR) actuator is always supplied in closed position;
- Fail Open Spring Return (SR) actuator is always supplied in opened position;
- Actuator position and rotation must be according to valve requirements and operations, especially for Spring Return (SR);
- Check valve position (open or closed) and its rotation direction;
- Before connecting actuator and valve, make sure that valve rotation is according with actuator operating rotation and upper shaft slot orientation;
- Before installation, actuator, valve and accessories must be clean and free of dirt;
- Remove protective labels from air feeding ports;

7.1 Valve/Actuator installation

7.1.1 Direct installation

Direct installation is the best solution to avoid play or clearance between valve and shaft. Direct installation needs same flanged standard connection on valve and actuator as well as same dimension of valve stem and actuator socket.

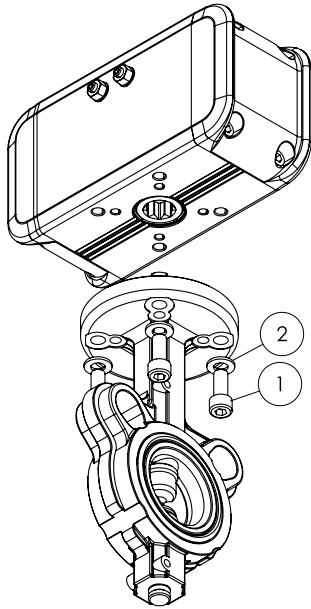

Installation:

- A. Pull reduction in valve stem (in case of reduction needs only);
- B. Put valve stem into the actuator socket;
- C. Verify correct connection to avoid play, clearance or interferences in between;
- D. Place screws (1) and relevant washers (2) and screw them in compliance with below torque indications;
- E. After installation, check actuator rotation direction for Double acting (DA) actuators;
- F. After installation, check actuator rotation direction and home position in case of Spring Return (SR);
- G. In case of discrepancy contact us;

7.1.2 Plate installation

If a direct installation is not possible because of discrepancy between actuators and valve flanges or because of power transmission differences, is it possible to use plates. Adapting plates make the installation easier and offer more space for actuator/valve installation.

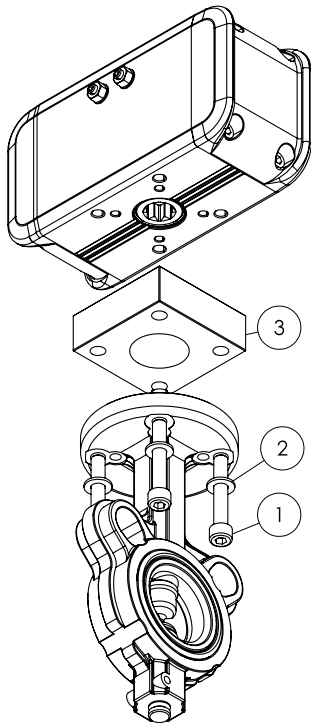

Installation:

- A. Place plate (3) on valve flange;
- B. Pull reduction in valve stem (in case of reduction needs only);
- C. Put valve stem into the actuator socket;
- D. Verify correct connection to avoid play, clearance or interferences in between;
- E. Place screws (1) and relevant washers (2) and screw them in compliance with below torque indications;
- F. After installation, check actuator rotation direction for Double acting (DA) actuators;
- G. After installation, check actuator rotation direction and home position in case of Spring Return (SR);
- H. In case of discrepancy contact us;

7.1.3 Bracket & Joint Installation

Bracket & Joint installation is suitable in case of valves/actuator space requirements, in presence of non-standard valve flange or valve stem, or generally in case of actuator/valve installation impossibility. Bracket is a stainless-steel drawn tubular with two holes for Joint passage and several holes for valve/actuator installation. Joint allows the connection of actuator shaft and valve stem. Bracket & Joint play or clearance must be as low as possible to ensure a correct actuator/valve power transmission.

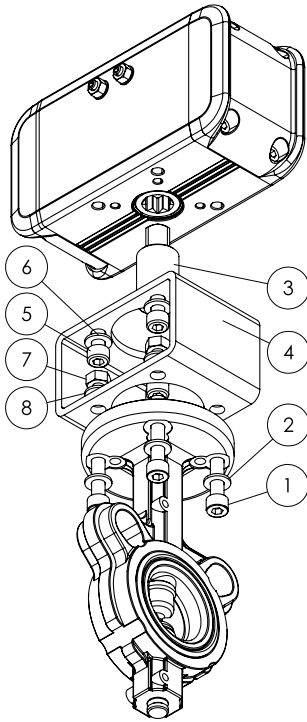

Installation:

- A. Place Bracket (4) on valve flange, ribs must be perpendicular to the pipe;
- B. Place screws (1) and relevant washers (2);
- C. Place nuts (7) and washers (8) and in correspondence to the screws;
- D. Lock the nuts using a wrench and screw them in compliance with below torque indications;
- E. Put valve stem into the joint socket (3);
- F. Put joint stem (3) into the actuator socket;
- G. Verify correct connection to avoid play, clearance or interferences in between;
- H. Place screws (5) and relevant washers (6) and screw them in compliance with below torque indications;
- I. After installation, check actuator rotation direction for Double acting (DA) actuators;
- J. After installation, check actuator rotation direction and home position in case of Spring Return (SR);
- K. In case of discrepancy contact us;

Torque indication

Flange type	Torque (Nm)
F03	5 - 6
F04	5 - 6
F05	9 - 10

Flange type	Torque (Nm)
F07	22 - 24
F10	46 - 50
F12	80 - 84

ACTUATECH actuator, with evacuation grooves on connection side is purposely designed to a direct installation. Evacuation grooves avoid any actuator damages caused by eventual draining fluids coming from valve stem.

7.2 Actuator/Valve controls: Rotation direction check and installation

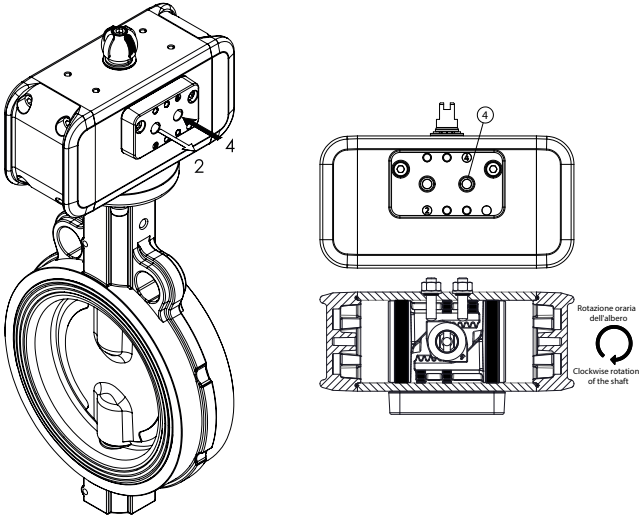
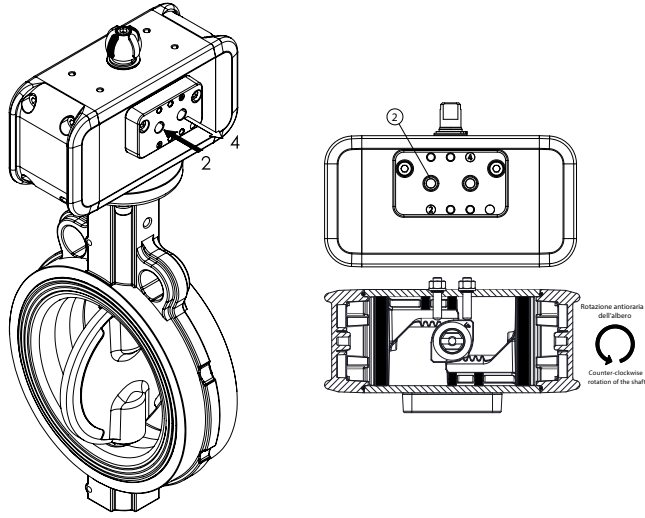
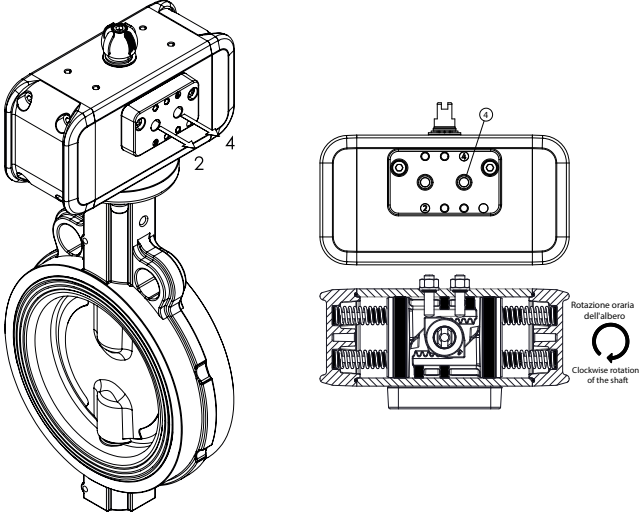
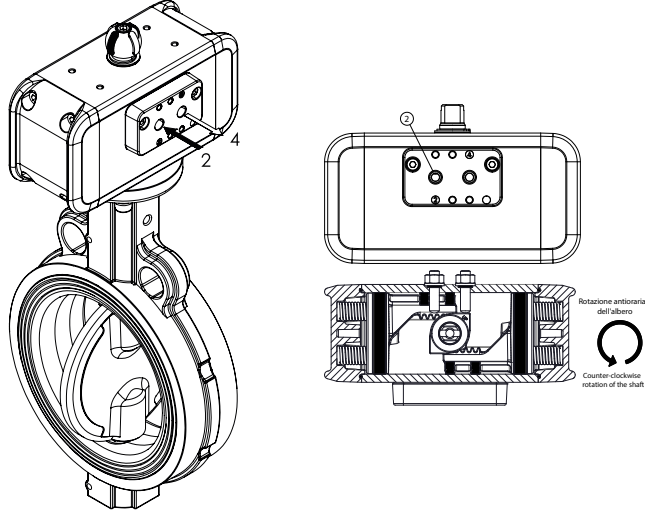
Double acting (DA) Closed valve	Double acting (DA) Opened valve
 <p>Rotazione oraria dell'albero Clockwise rotation of the shaft</p>	 <p>Rotazione antioraria dell'albero Counter-clockwise rotation of the shaft</p>
Spring Return (SR) Fail Close Closed valve	Spring Return (SR) Fail Close Opened valve
 <p>Rotazione oraria dell'albero Clockwise rotation of the shaft</p>	 <p>Rotazione antioraria dell'albero Counter-clockwise rotation of the shaft</p>

Spring Return (SR) Fail Open Closed valve **Spring Return (SR) Fail Open Opened valve**

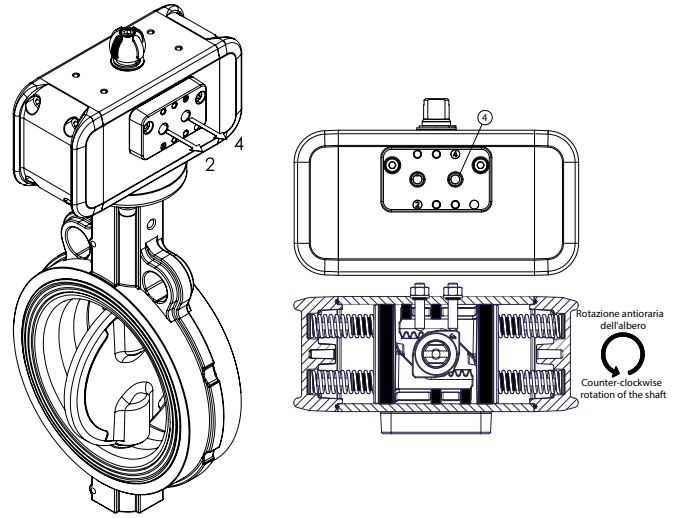
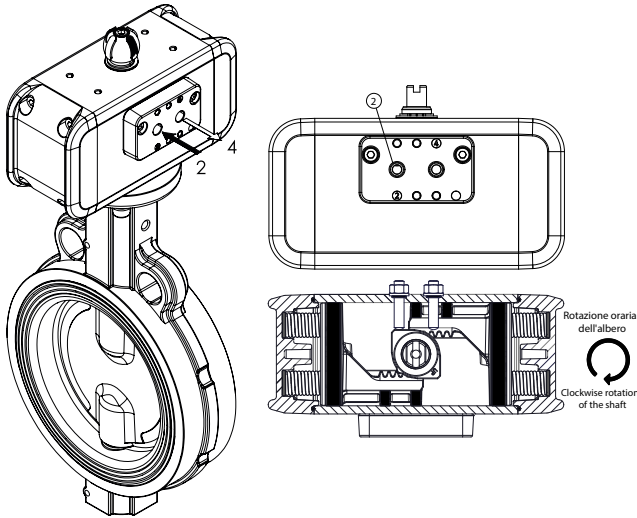

8. OPENING AND CLOSING ANGLE SETTING

RP actuators rotation angle is nominally 90° with a ± 5° adjusting stroke: closing setting from -5° to +5° and opening setting from 85° to 95°. Before any operation, take the pressure off, disconnect air feeding and make sure that air ports have been completely vented.

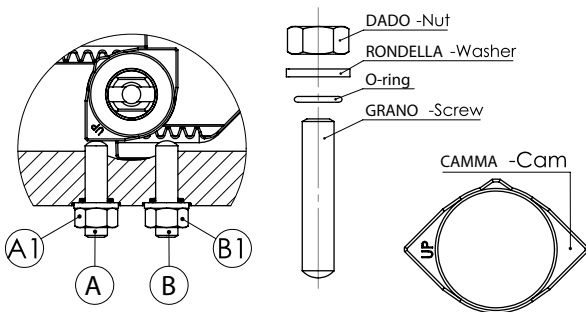
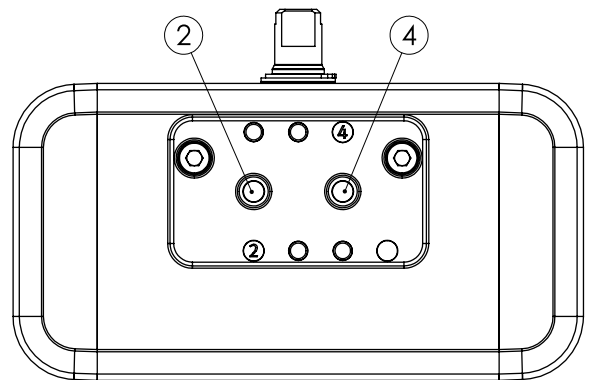
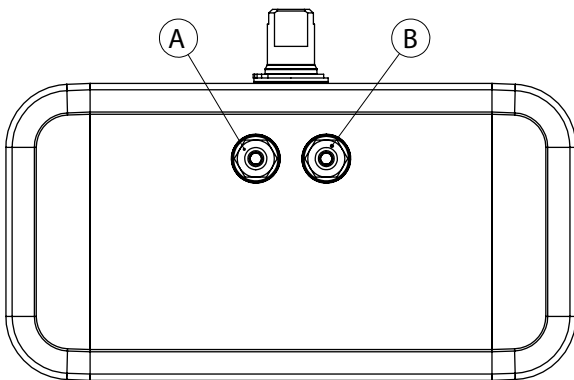

Adjusting screw nuts				
Size	Thread	Grub screw key	Nut key	Torque (Nm)
RP 10	M6	ch.3	ch.10	10 - 11
RP 20				
RP 40				
RP 60	M8	ch.4	ch.13	22 - 25
RP 80				
RP 120				
RP 160	M10	ch.5	ch.16	38 - 43
RP 240	M12	ch.6	ch.18	85 - 90
RP 300				
RP 480	M14	ch.6	ch.21	110 - 115

8.1 Double acting (DA) angle setting instruction

Opening Setting instruction:

- A. Take pressure off, disconnect air feeding and make sure that air ports have been completely vented;
- B. Act on the grub screw (see arrow);
- C. Unloose counter-nut (A1);
- D. Feed port (2) with a low pressure (for a small movement only) in order to put pistons in home position;
- E. Using an Allen wrench, screw or unscrew grub screw (A) to obtain angle setting required (range $\pm 5^\circ$);
- F. Once adjusted, lock the grub screw (A) using an Allen wrench and screw counter-nut (A1) according to torque indications;

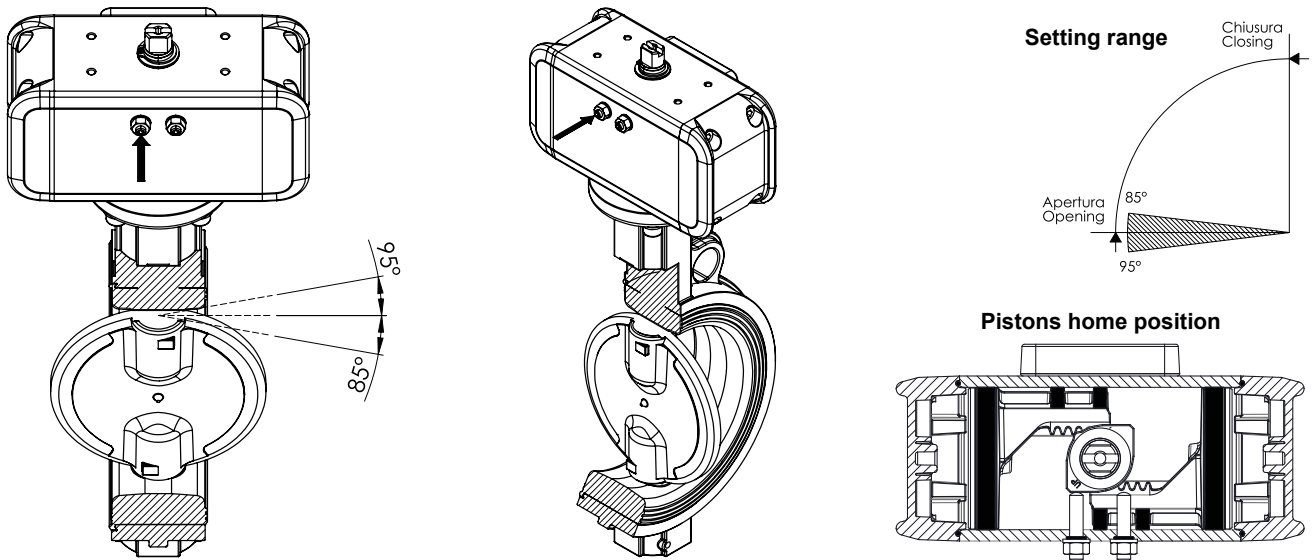

Closing Setting instructions:

- A. Take pressure off, disconnect air feeding and make sure that air ports have been completely vented;
- B. Act on the grub screw (see arrow);
- C. Unloose counter-nut (B1);
- D. Feed port (4) with a low pressure (for a small movement only) in order to put pistons in home position;
- E. Using an Allen wrench, screw or unscrew grub screw (B) to obtain angle setting required (range $\pm 5^\circ$);
- F. Once adjusted, lock the grub screw (B) using an Allen wrench and screw counter-nut (B1) according to torque indications;

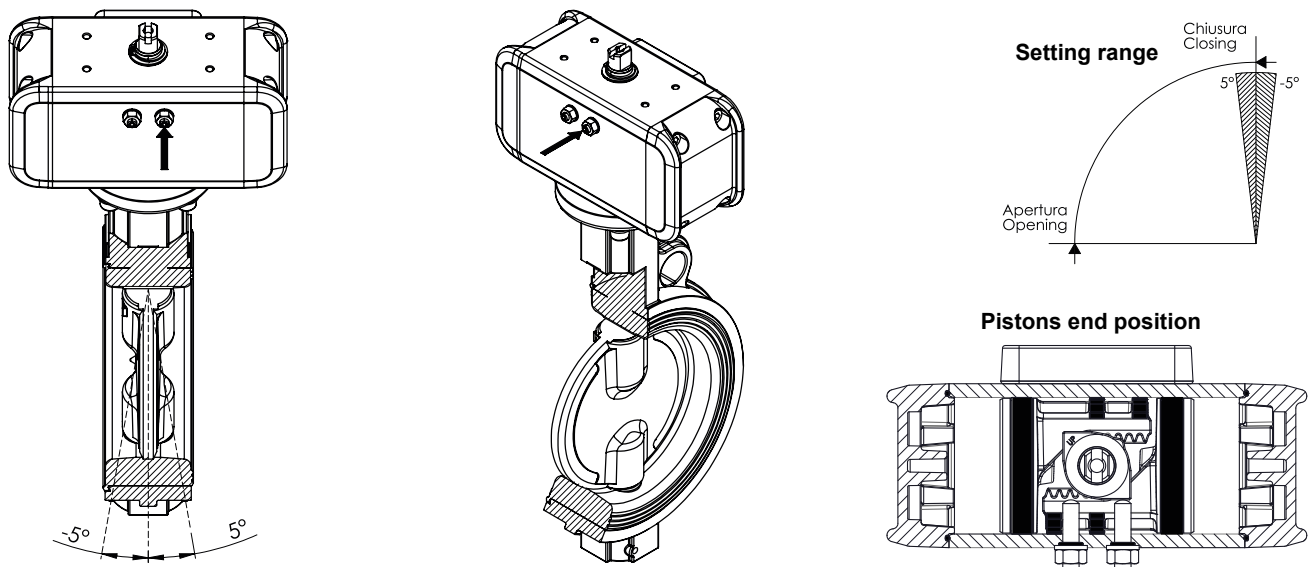

8.2 Spring Return (SR) Fail Close angle setting instructions

Opening Setting instruction:

- A. Take pressure off, disconnect air feeding and make sure that air ports have been completely vented;
- B. Make sure that on air port (4) has been assembled a filter and its conditions (filter must not be clogged);
- C. Act on the grub screw (see arrow);
- D. Unloose counter-nut (A1);
- E. Feed port (2) with a low pressure (for a small movement only) in order to put pistons in end position;
- F. Using an Allen wrench, screw or unscrew grub screw (A) to obtain angle setting required (range $\pm 5^\circ$);
- G. Once adjusted, lock the grub screw (A) using an Allen wrench and screw counter-nut (A1) according to table torque indications;

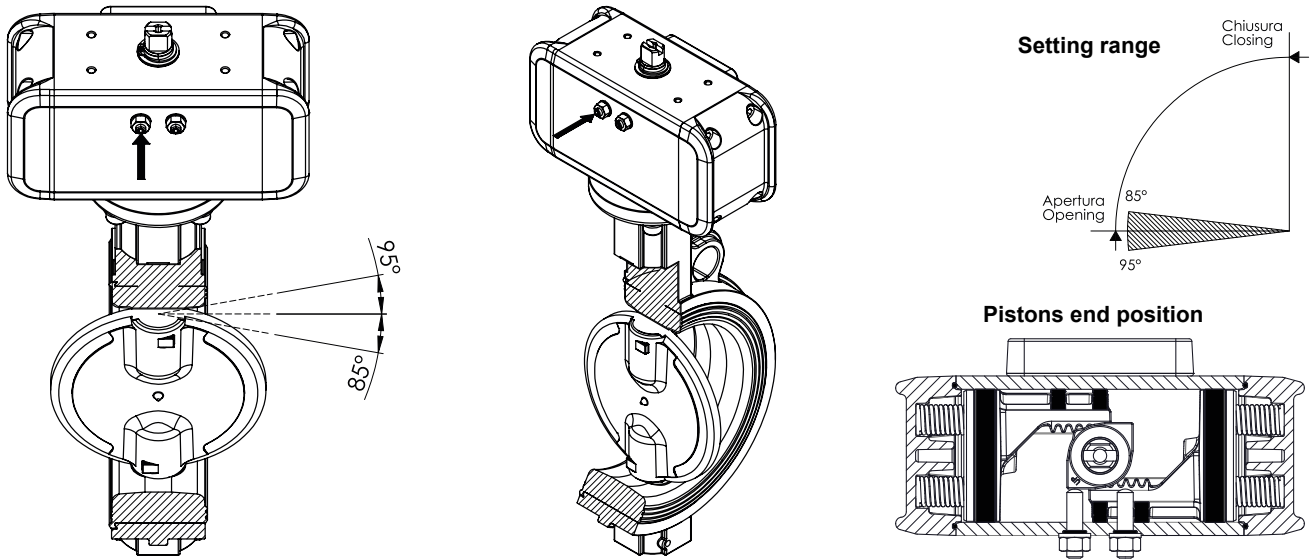

Closing Setting instructions:

- A. Take pressure off, disconnect air feeding and make sure that air ports have been completely vented;
- B. Make sure that on air port (4) has been assembled a filter and its conditions (filter must not be clogged);
- C. Act on the grub screw (see arrow);
- D. Unloose counter-nut (B1);
- E. Using an Allen wrench, screw or unscrew grub screw (B) to obtain angle setting required (range $\pm 5^\circ$);
- H. Once adjusted, lock the grub screw (B) using an Allen wrench and screw counter-nut (B1) according to table torque indications;

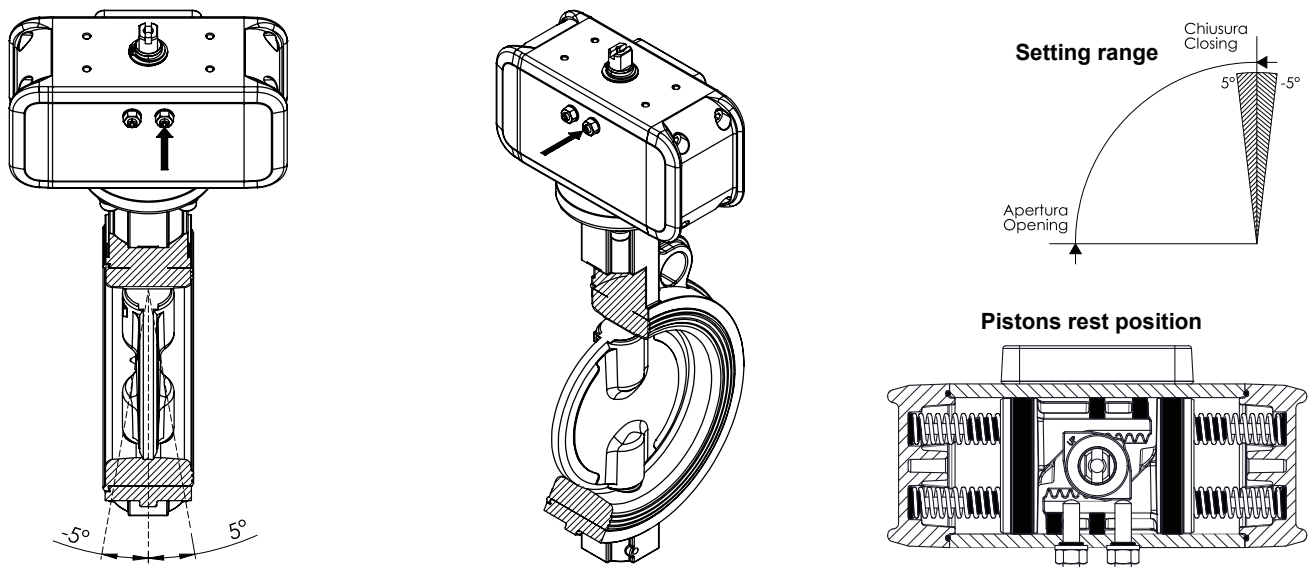

8.3 Spring Return (SR) Fail Open angle setting instructions

Opening Setting instruction:

- Take pressure off, disconnect air feeding and make sure that air ports have been completely vented;
- Make sure that on air port (4) has been assembled a filter and its conditions (filter must not be clogged);
- Act on the grub screw (see arrow);
- Unloose counter-nut (A1);
- Using an Allen wrench, screw or unscrew grub screw (A) to obtain angle setting required (range $\pm 5^\circ$);
- Once adjusted, lock the grub screw (A) using an Allen wrench and screw counter-nut (A1) according to table torque indications;

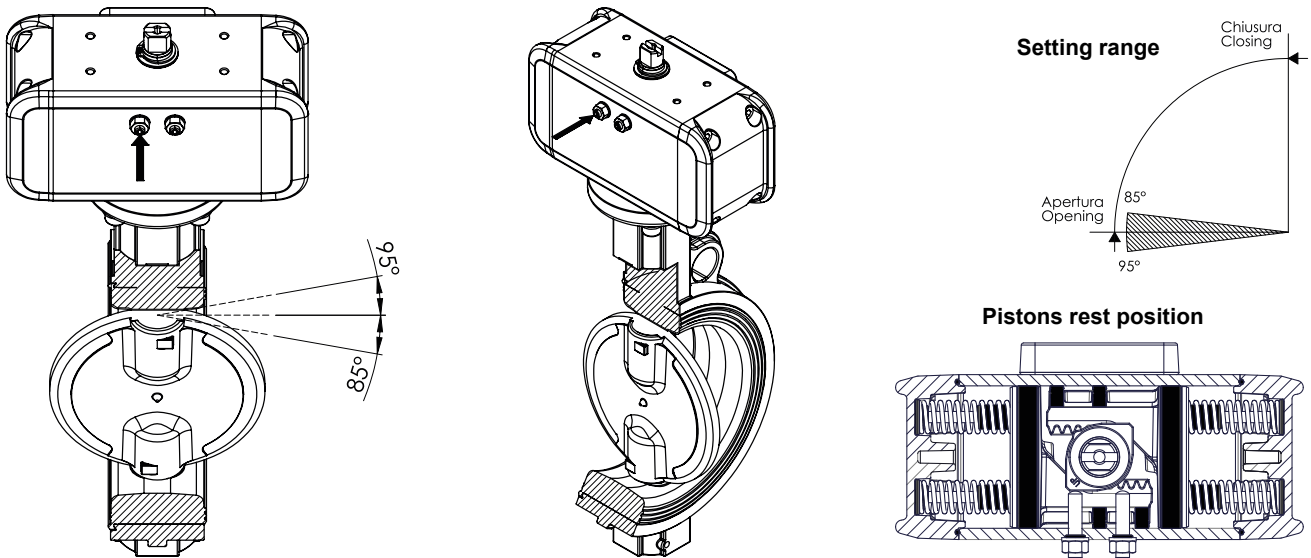

Closing Setting instructions:

- Take pressure off, disconnect air feeding and make sure that air ports have been completely vented;
- Make sure that on air port (4) has been assembled a filter and its conditions (filter must not be clogged);
- Act on the grub screw (see arrow);
- Unloose counter-nut (B1);
- Feed port (2) with a low pressure (for a small movement only) in order to put pistons in end position;
- Using an Allen wrench, screw or unscrew grub screw (B) to obtain angle setting required (range $\pm 5^\circ$);
- Once adjusted, lock the grub screw (B) using an Allen wrench and screw counter-nut (B1) according to table torque indications;

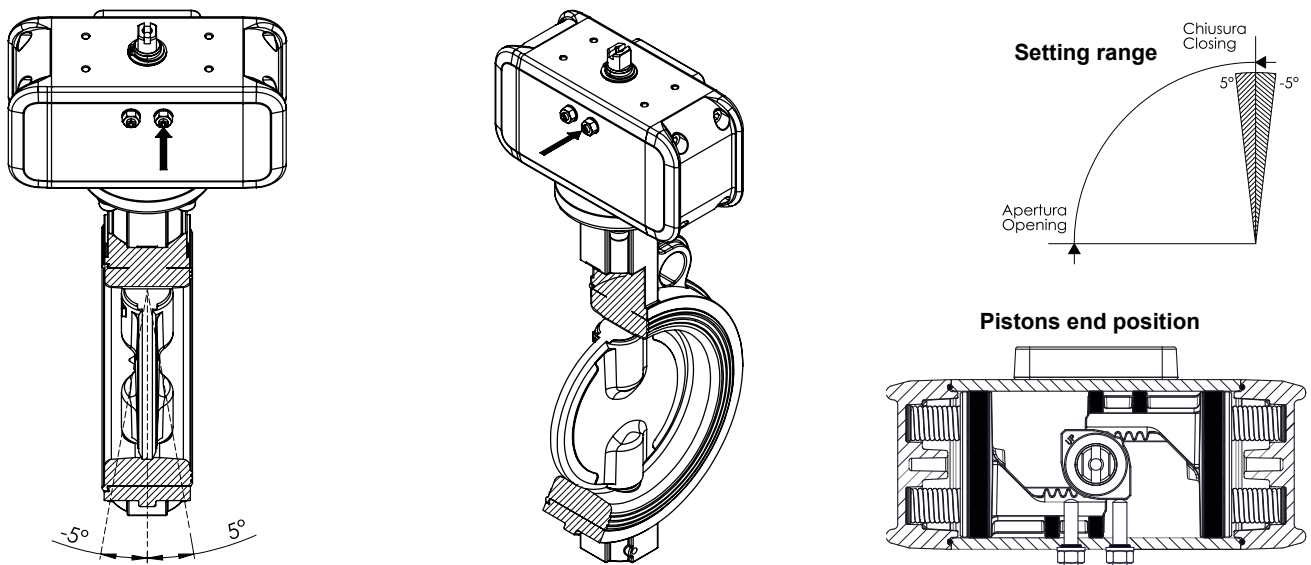

9. MATERIALS AND DURABILITY

Number of cycles as per EN15714-3 2009 (see table below).

Nominal torque a Nm	Piston or vane actuator Minimum number of cycles b	Maximum stroking time for testing, based on 0-90° s
≤125	500 000 c	3
≤1 000	500 000	5
≤2 000	250 000	8
≤8 000	100 000	15
≤32 000	25 000	20
≤63 000	10 000	30
≤125 000	5 000	45
≤250 000	2 500	60

a Based on EN ISO 5211.

b One cycle consists of nominal 90° angular travel in both directions (i.e. 90° to open + 90° to close). For angular travel other than 90°, the endurance shall be agreed between the purchaser and the manufacturer/supplier.

c For thermoplastic actuators the minimum number of cycles shall be 250 000.



In the case of maintenance, see section 10.

9.1 Actuator components and bill of materials

9.1.1 Double action actuator (DA)

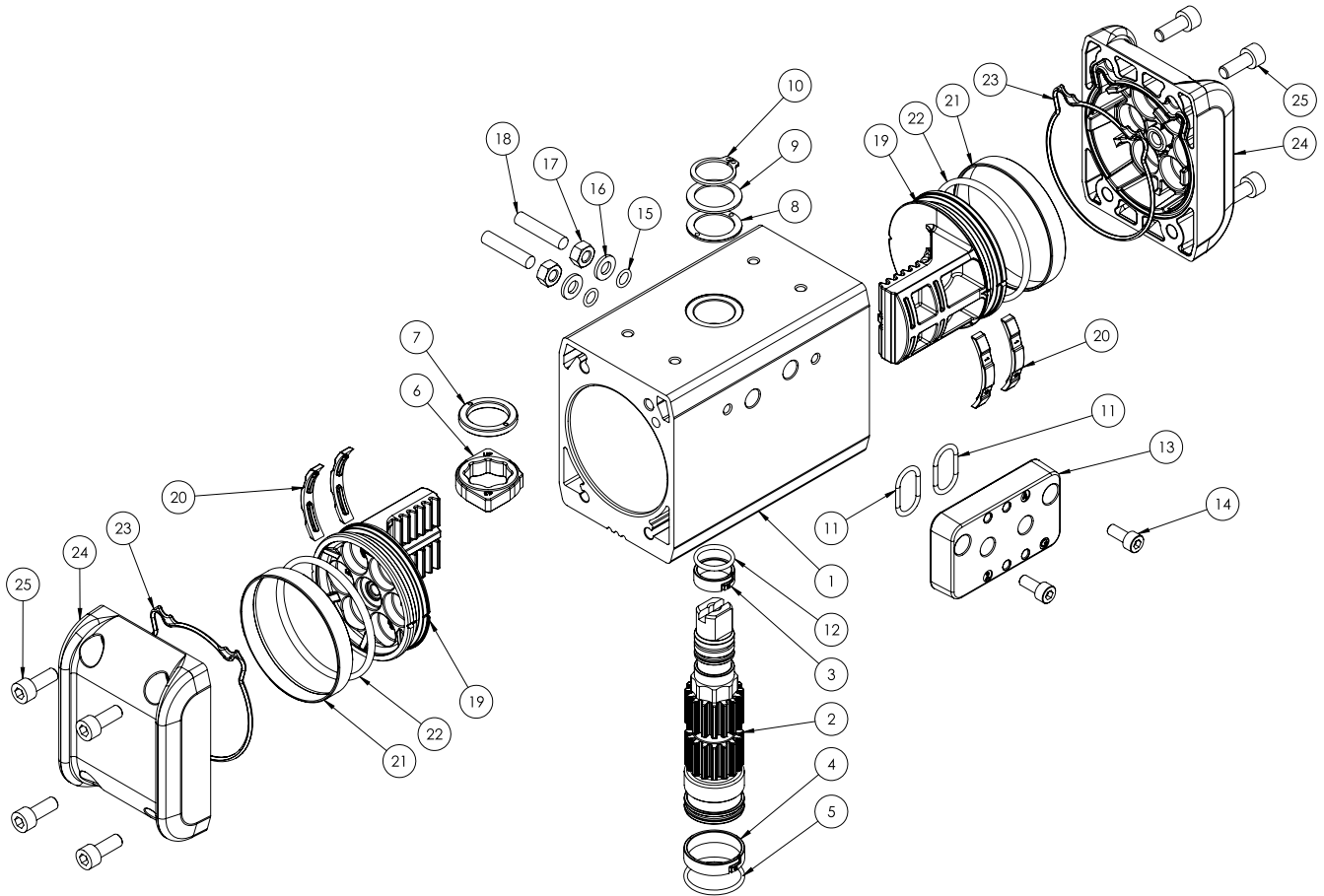

POS.	Description	Q.	Row Material (standard actuator)
1	Cylinder	1	Aluminium alloy
2	Shaft	1	Steel alloy
3*	Slide ring (upper shaft support)	1	Acetal resin
4*	Slide ring (lower shaft support)	1	Acetal resin
5*	O-Ring (lower shaft sealing)	1	Nitrile rubber
6	Cam	1	Steel alloy
7*	Internal support ring	1	Acetal resin
8*	External support ring	1	Acetal resin
9	Washer	1	Stainless-steel
10*	Seeger	1	Stainless-steel
11*	O-Ring**	2	Nitrile rubber
12*	O-ring (upper sealing shaft)	1	Nitrile rubber
13	Namur plate**	1	Aluminium alloy
14	Screw**	2	Stainless-steel
15*	O-Ring	2	Nitrile rubber
16*	Washer (limit stroke)	2	Stainless-steel
17*	Nut (limit stroke)	2	Stainless-steel
18*	Grub screw (limit stroke)	2	Stainless-steel
19	Piston	2	Aluminium alloy
20*	Piston support leg	4	Acetal resin
21*	Dynamic seal	2	Polyurethan
22*	O-Ring	2	Nitrile rubber
23*	End-cap O-ring	2	Nitrile rubber
24	Cap	2	Aluminium alloy
25	Screw	8	Stainless-steel

* Components of spare part kit. ** Not present for some models, see code table.

ACTUATECH S.p.A.

Via S. Lorenzo, 70, 25069 Villa Carcina (BS) Italy
 Ph. +39 030 8908142 · Fax +39 030 8908143 · actuatech@actuatech.com · www.actuatech.com

9.1.2 Spring Return actuator (SR)

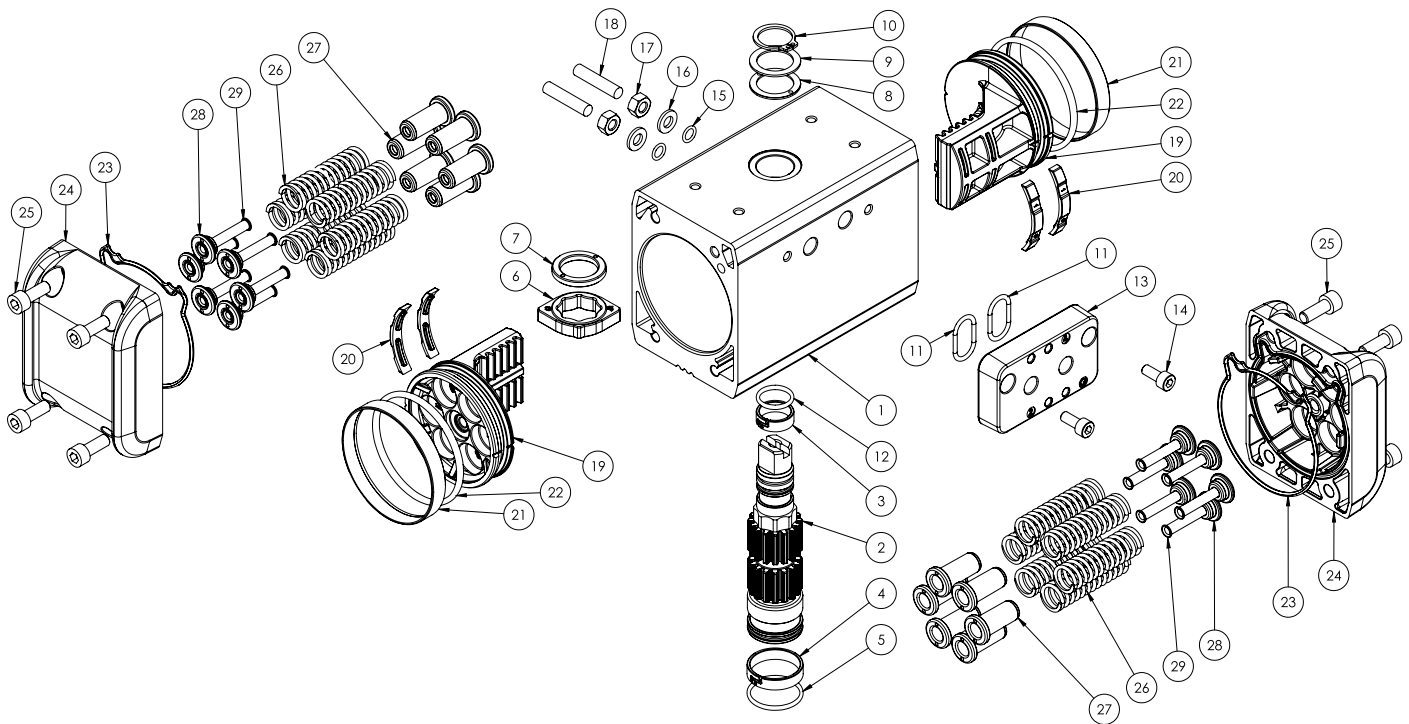

POS.	Description	Q.	Row Material (standard actuator)
1	Cylinder	1	Aluminium alloy
2	Shaft	1	Steel alloy
3*	Slide ring (upper shaft support)	1	Acetal resin
4*	Slide ring (lower shaft support)	1	Acetal resin
5*	O-Ring (lower shaft sealing)	1	Nitrile rubber
6	Cam	1	Steel alloy
7*	Internal support ring	1	Acetal resin
8*	External support ring	1	Acetal resin
9	Washer	1	Stainless-steel
10*	Seeger	1	Stainless-steel
11*	O-Ring**	2	Nitrile rubber
12*	O-ring (upper sealing shaft)	1	Nitrile rubber
13	Namur plate**	1	Aluminium alloy
14	Screw**	2	Stainless-steel
15*	O-Ring	2	Nitrile rubber
16*	Washer (limit stroke)	2	Stainless-steel
17*	Nut (limit stroke)	2	Stainless-steel
18*	Grub screw (limit stroke)	2	Stainless-steel
19	Piston	2	Aluminium alloy
20*	Piston support leg	4	Acetal resin
21*	Dynamic seal	2	Polyurethan
22*	O-Ring	2	Nitrile rubber
23*	End-cap O-ring	2	Nitrile rubber
24	Cap	2	Aluminium alloy
25	Screw	8	Stainless-steel
26	Spring	12	Steel alloy
27	Spring cartridge long	12	Acetal Resin
28	Spring cartridge short	12	Acetal Resin
29	Spring cartridge tube	12	Brass

* Components of spare part kit.

** Not present for some models, see code table.

The number of springs varies according to the model.

Excluded from the kit it is possible to request spare spring cartridge.

ACTUATECH S.p.A.

Via S. Lorenzo, 70, 25069 Villa Carcina (BS) Italy

Ph. +39 030 8908142 · Fax +39 030 8908143 · actuatech@actuatech.com · www.actuatech.com











10. MAINTENANCE

ACTUATECH actuator, if installed and used properly, does not require maintenance, as it is provided with enough lubrication for standard long-life. During maintenance and reassembling, we recommend using, for standard version, TECNOLUBE SYNTHY POLYMER 402, or equivalents. For low and high temperature actuators contact us.

The components for the actuator maintenance are supplied in the ACTUATECH spare part kit (see section 9 exploded views).

ACTUATECH declines any responsibility for the products repaired by third parties.

10.1 Safety notice for maintenance

-  **Before carrying out any type of maintenance, carefully read the safety notes in section 6;**
-  Before actuator disassembly operation, take pressure off, disconnect air feeding and make sure that air ports have been completely vented;
-  Actuator must be free of pneumatic and electric connections and must be disconnected from the valve;
-  Spare parts must be replaced by qualified personnel and with appropriate tools only;
-  In the case of Spring return actuators the springs can be under tension. Do not attempt to act manually on the actuator when the actuator is under pressure;
-  In case of Spring return actuator, springs must be in FAIL position;
-  Do not disconnect the actuator from a line under pressure or if still under pressure;
-  Do not remove any component if actuator is still under pressure or installed in the line;
-  Do not use compressed air to remove the pistons from the actuator body;
-  Do not shorten the cover fixing screws, use only screws with original length, use original spare parts supplied by ACTUATECH or by authorized distributors;
-  Do not make adjustments beyond $\pm 5^\circ$ on each side;

10.2 Spare parts replacing

In case your product does not meet above configurations, please look at ACTUATECH catalogue or contact us.

Disassembly instructions

A. Unloose cap screws (25) crossways to remove the caps (24). If unloosing process looks too difficult, stop the operation, check carefully if actuator is really free of air (completely vented) and/or springs are really in rest position. Cap (24) has a graved seat where is placed a profiled gasket (23). Check gasket and graved seat.

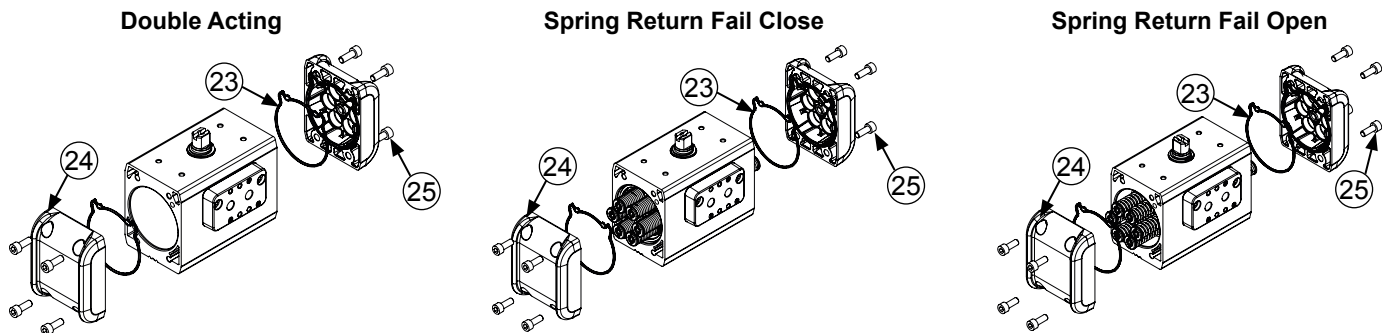

- B.** Unloose completely counter-nut (17) using a wrench. Unloose completely grub screw (18) using an Allen wrench.
C. Remove washer (16) and O-Ring (15). Check counter-nut and grub screw.

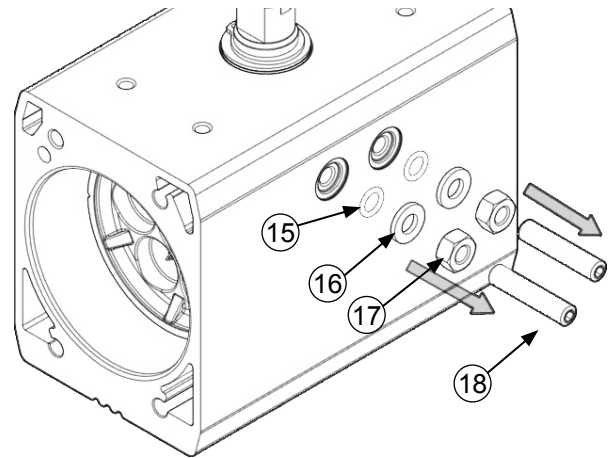
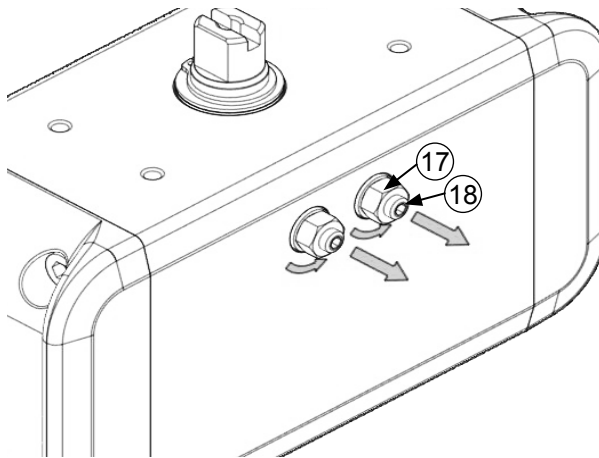

- D.** Lock the actuator into a vice, rotate the shaft (see below pictures) until pistons look completely free from shaft gear, then remove the pistons from the cylinder. Do not use air to remove the pistons, it might cause severe personal injuries.

**Double Acting (DA) and
 Spring Return Fail Close**

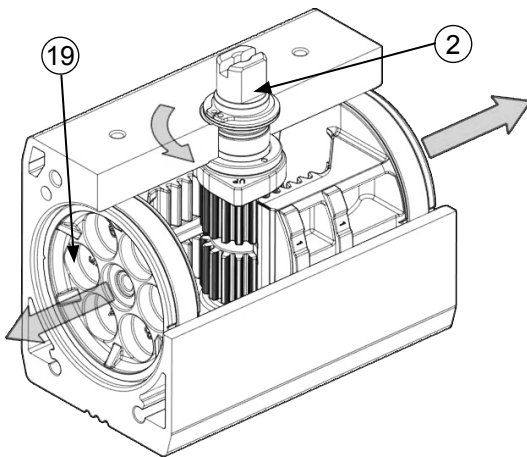

Spring Return Fail Open

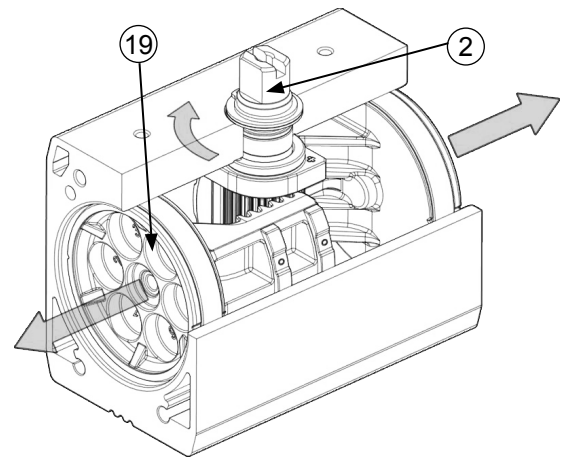

- E.** Check dynamic seal (21) and piston support leg (20). Do not use sharpened tools to replace the components because they could generate irreversible scrapes or grooves.

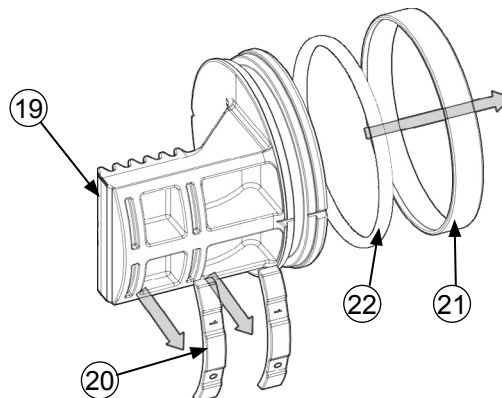

- F. Remove Seeger (10) using expanding pliers.
- G. Separate washer (9) from external support ring (8) from cylinder using a flat bladed screwdriver.
- H. Pull down shaft (2) as shown in below picture. During this process hold cam (6) and internal support ring (7). Cam fall could cause irreversible scrapes or grooves in cylinder inner surface.

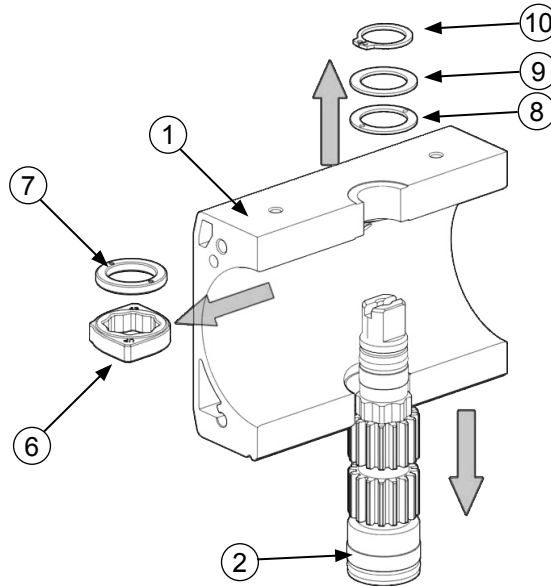

- I. Pull up O-ring (12) and slide ring (3) and remove them.
- J. Pull down O-ring (5) and slide ring (4) and remove them.
- k. Do not use sharp tools to replace the components because they could generate irreversible scrapes or grooves on the shaft.

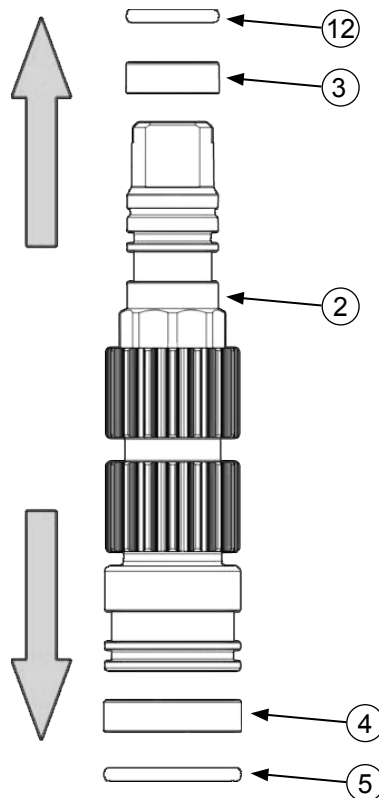

L. Unloose screws, take off Namur plate (13) and relevant O-Rings (11). Namur plate (13) has graved seats where are placed two O-Rings. Not all actuator sizes are equipped with Namur plate (see section 3).

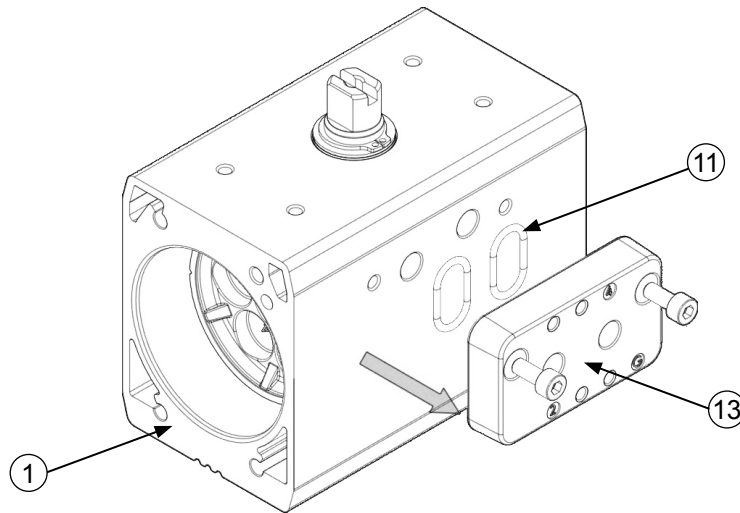

M. Disassembled components must be cleaned and verified before reassembly. In case of advanced state of wear o break, replace the components using ACTUATECH replacement Kit. If it is necessary to replace parts not present in the spare part kit, contact ACTUATECH.

! Degreasing process must be done using only specific cleaners suitable for rubber. Do not use solvents, they will irreversibly damage rubber components.

Assembly instructions

A. To avoid damages, O-ring (22) and dynamic seal (21) must be greased and assembled on the relevant piston seat using an easy-sliding tool (see image).

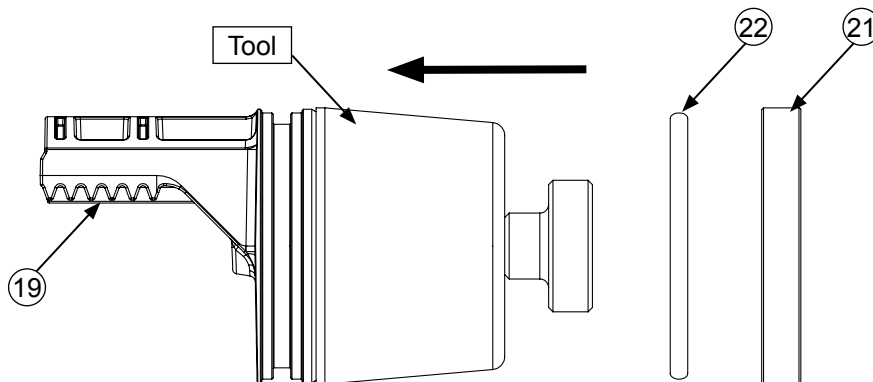

B. Grease pistons (19) on tightening surface (21). Lubricate piston support leg (20) and put them on relevant seats.

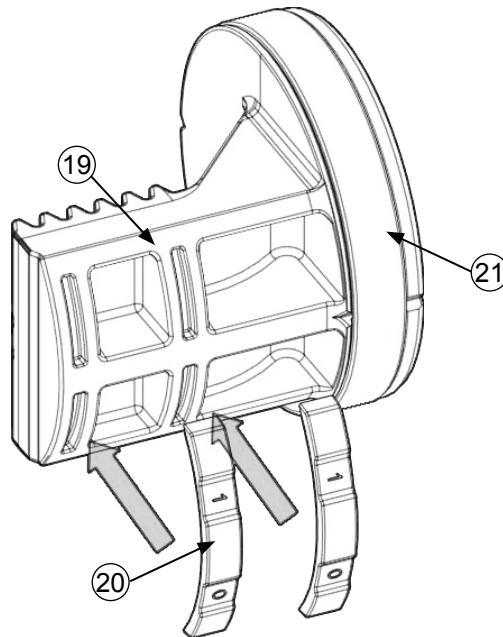

C. Lubricate O-ring (12+5) and slide rings (3+4).

D. Grease piston gear, slide rings seats and shaft O-Ring (2).

E. Pull down upper slide ring (3) and O-Ring (12), see beside image.

F. Pull up lower slide ring (4) and O-ring (5), see beside image.

G. Slide rings and O-Rings must be assembled manually, do not use sharp tools to replace the components because they could generate irreversible components damages.

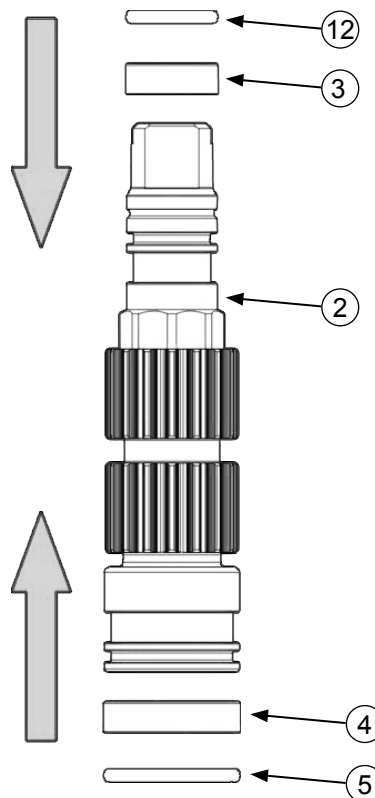

- H. Grease completely inner cylinder surface (1) and shaft passage holes.
- I. Lubricate internally and internal support ring (7) and cam (6).
- J. Grease external support ring (8) and washer (9).
- K. Pull up the shaft in the lower cylinder hole, then insert cam (6) and internal support ring (7) according to below instructions.
- L. Pull up the shaft in the upper cylinder hole and insert external support ring (8), washer (9) and Seeger (10).

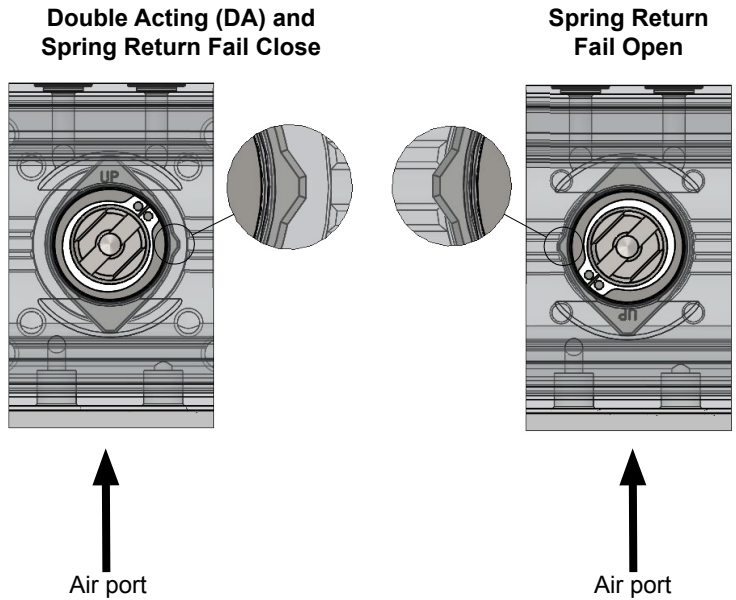
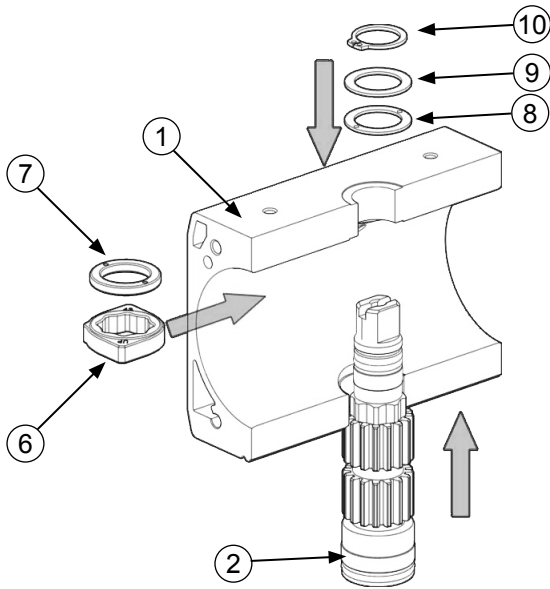

- M. According to actuator configuration, place shaft (2) and cam (6) as below indicated.

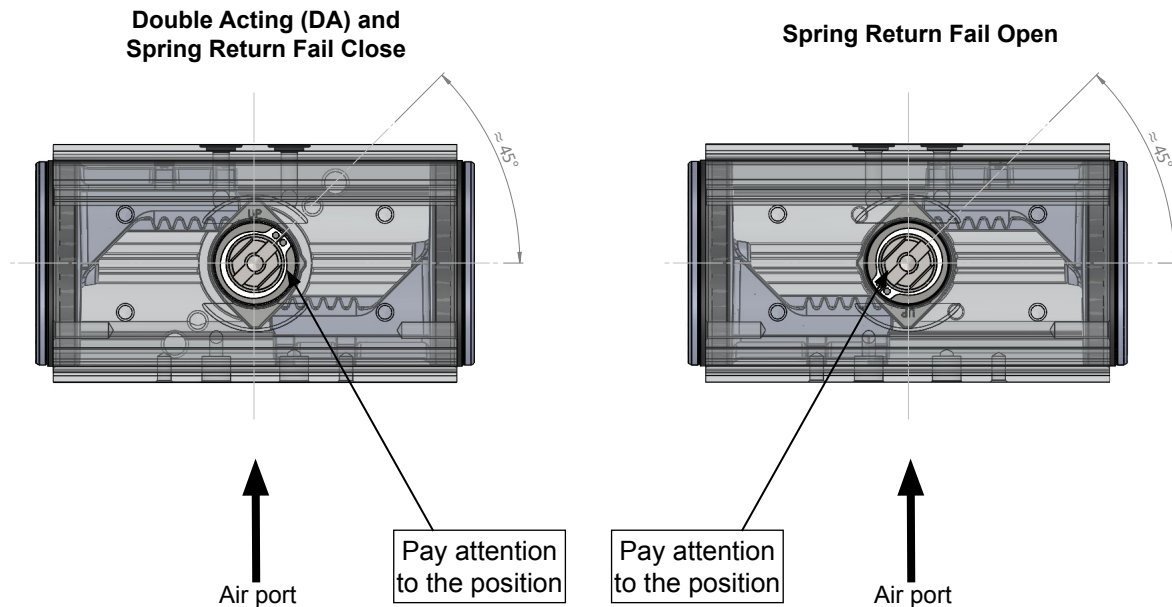

N. According to actuator configuration, position piston (19) using a conical tool in order to put in contact the first piston tooth and shaft gear (2). Operation must be done for both pistons.

O. Push both pistons inside the cylinder (1) manually, then rotate shaft to gear shaft and pistons.

P. Lock the actuator into a vice and, using a wrench, rotate the shaft to verify:

- Easy shaft rotation,
- Correct rotation direction,
- Closing angle range $0 \pm 5^\circ$ (looking at shaft slot),
- Opening angle range $90 \pm 5^\circ$ (looking at shaft slot).

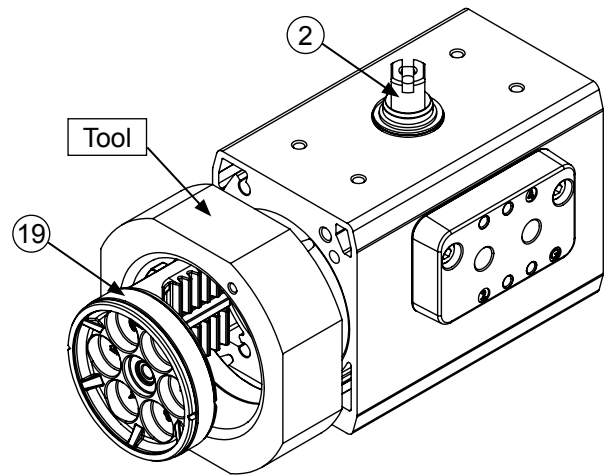

Q. For Spring Return (SR) actuators follow the further indications.

Model	Spring quantity	Spring location on pistons				Piston
		Left		Right		
RS20	4	2-5		2-5		
RS25	5	2-5		2-4-6		
RS30	6	2-4-6		2-4-6		
RS35	7	2-4-6		1-3-4-6		
RS40	8	1-3-4-6		1-3-4-6		
RS45	9	1-3-4-6		1-3-4-5-6		
RS50	10	1-3-4-5-6		1-3-4-5-6		
RS55	11	1-3-4-5-6		All		
RS60	12	All		All		

R. Assemble caps, if necessary, replace O-Ring (23) placed in seat (24) and grease it. Connect caps to cylinder fastening screws (25) crossway and in accordance to below torque instructions.

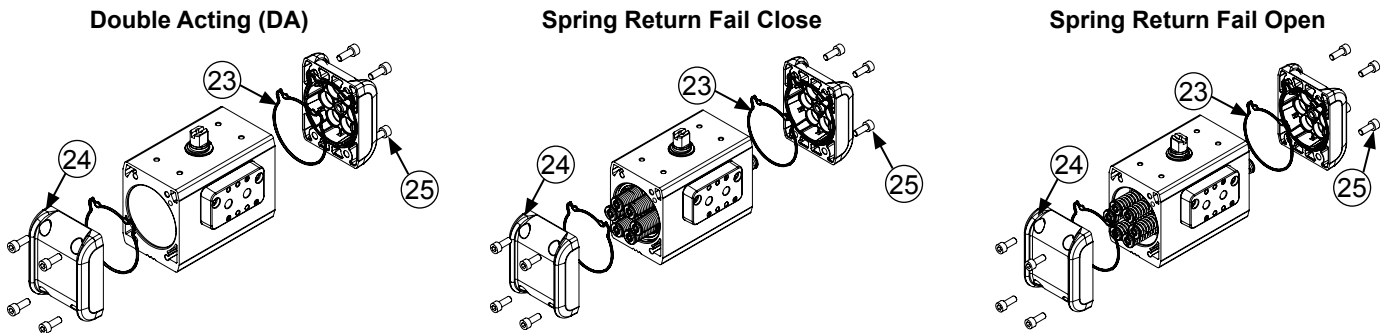

S. Grease O-ring (15).

T. Screw hexagon nut (17) for some threads on grub screw (18), insert washer (16) and O-Ring (15) along the grub screw (18).

U. Screw grub screw (with pre-assembled components) in cylinder threaded hole using an Allen wrench. Pay attention, screw starting from rounded end grub screw.

V. See angle setting procedure on section 8.

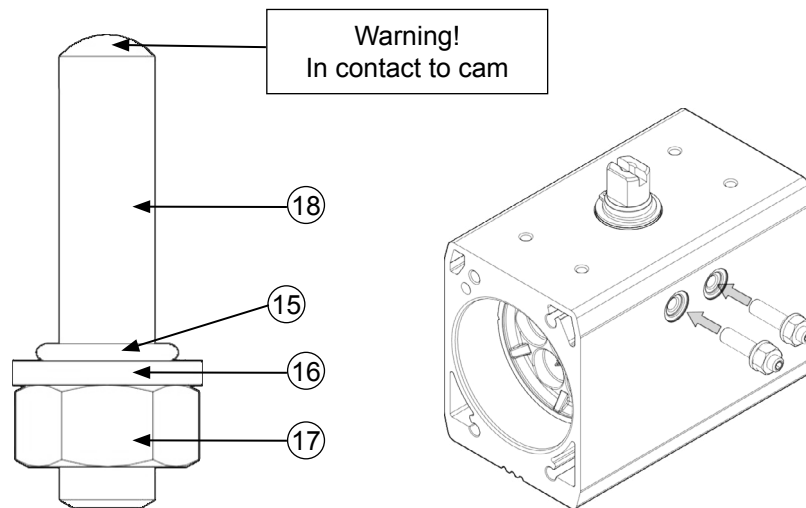

W. Grease O-Ring (11).

X. Rest Namur plate (13) to cylinder surface (1) and fasten screws (14) in accordance to below torque instructions. Not all actuator sizes are equipped with Namur plate (see section 3).

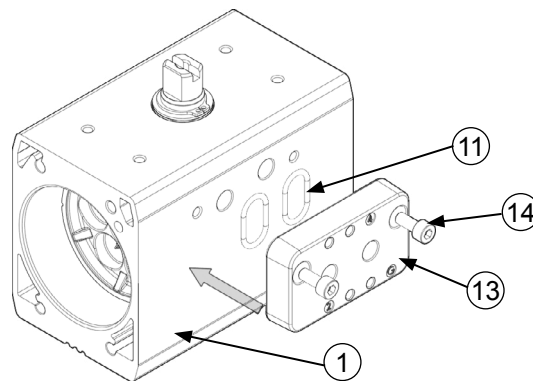

End cap screw								
Size	Thread	key	Torque (Nm)		Size	Thread	key	Torque (Nm)
RP 10	M5	Ch.4	6-8		RP 120	M8	ch.6	22-25
RP 20				RP 160				
RP 40	M6	Ch.4	10-11		RP 240			
RP 60				RP 300	M10	ch.8	38-43	
RP 80				RP 480				

Namur plate screw			
Size	Thread	key	Torque (Nm)
For all models (if supplied)	M5	Ch.4	6-8

11. ATEX SPECIFICATION

In conformance with the European Directive ATEX 2014/34 UE for the suitability of the equipment intended for the use in Potentially Explosive Atmosphere, ACTUATECH declare the conformity of the part-turn actuator of the above mentioned Atex directive in the limits of its Classification and Zone Classification.

A) Equipment classification:

- Equipment Group II;
- Category 2;
- Gas Zone 1-2, Dust Zone 21-22;
- Type of protection: Ex h (with constructional safety 'c');
- Gas group IIC (IIB with non conductive coating thickness > 0,2mm);
- Dust group IIIC;
- Temperature Class T6...T3 (as per following table);
- EPL: Gb (Gas), Db (Dust);

T. max fluid and T. max ambient	Temperature Class	Max surface temperature
-50°C ≤ T ≤ 60°C (-58°F ≤ T ≤ 140°F)	T6	T85°C (185°F)
60°C < T ≤ 75°C (140°F ≤ T ≤ 167°F)	T5	T100°C (212°F)
75°C < T ≤ 110°C (167°F ≤ T ≤ 230°F)	T4	T135°C (275°F)
110°C < T ≤ 150°C (*) (230°F ≤ T ≤ 302°F)	T3	T175°C (347°F)

(*) FKM SEALS

B) Equipment marking:



Whenever the actuator may be installed in the Potentially Explosive Atmosphere the operator before starting the installation must observe the suitability of the equipment classification and special installation instruction included that follow the actuator. In case of instruction missing or any doubts please call the ACTUATECH technical department.

C) Equipment technical specification:

Max operating pressure	8 bar (116 psi)
Ambient temperature T6	$-50^{\circ}\text{C} \leq T_a \leq 60^{\circ}\text{C}$ ($-58^{\circ}\text{F} \leq T \leq 140^{\circ}\text{F}$)
Ambient temperature T5	$60^{\circ}\text{C} < T_a \leq 75^{\circ}\text{C}$ ($140^{\circ}\text{F} \leq T \leq 167^{\circ}\text{F}$)
Ambient temperature T4	$75^{\circ}\text{C} < T_a \leq 110^{\circ}\text{C}$ ($167^{\circ}\text{F} \leq T \leq 230^{\circ}\text{F}$)
Ambient temperature T3	$110^{\circ}\text{C} < T_a \leq 150^{\circ}\text{C}$ ($230^{\circ}\text{F} \leq T \leq 302^{\circ}\text{F}$)
Max working frequency	1 Hz
Materials	All aluminium alloys used contain less than 7,5% magnesium (Mg) by mass
Seals	NBR (Standard version) FKM (High Temperature version) FVMQ (Low Temperature version)

12. ACTUATORS SPECIAL VERSIONS

ACTUATECH manufactures and supplies special actuator configurations for specific use and environment.

External protections.

All standard version could be supplied with different external protection according to ambient working condition (see ACTUATECH catalogue or contact our sales department).

13. STORAGE

ACTUATECH actuators packaging is designed to provide protection during shipment, however, they can be damaged in transport. Before to store them, verify eventual shipping damages. Keep actuators in their original packaging during storage. It is recommended to keep actuators in a dry and clean environment at temperatures $-10^{\circ}\text{C} \div 60^{\circ}\text{C}$ ($14^{\circ}\text{F} \div 140^{\circ}\text{F}$). Actuators have two air ports, which are closed by labels for prevent dust or solid particles incoming during storage. If actuators should be stored for a long period before installation, it is recommended to stroke them periodically to prevent seals damages.

14. TROUBLE SHOOTING

Potential effect of failure	Potential cause of failure	Solution
Loss or reduction of the supplied torque	Lack of supply	Verify actuator connection to pneumatic supply line
	Air supply not enough to produce required torque	Verify that supply pressure value corresponds to operation requirements (see actuator label)
Leaks from the stem upper or lower seals	Stem O-ring damage	Seals replacement (see section 10)
	Cylinder damage	Contact us for repair
	Shaft damage	
Leakage form cylinder caps	Seals damage	Seals replacement (see section 10)
Leakage from the ports afte manoeuvre	Piston seal damage	Pistons seals replacement (see section 10)
	Cylinder damage	Contact us for repair
Leakage form plate	Seals damage	Seals replacement (see section 10)
Insufficient valve rotation	Increase of valve manoeuvre torque	Verify valve release torque and replacement possibility
	Air supply not enough to produce required torque	Verify that supply pressure value corresponds to operation requirements (see actuator label)
	Incorrect adjustment	Adjust the actuator (see section 8)
	Wrong connection between actuator and valve stem	Check connection elements between valve and actuator

15. DISPOSAL OF PRODUCTS AT THE END OF THEIR LIFE CYCLE

ACTUATECH actuators are designed to be completely disassembled at end of their life. Components can be separated to be recovered or disposed. Raw materials have been selected in order to ensure minimal environmental impact and components are not contaminated by hazardous substances to grant health and safety of operators, users, installers and maintenance workers.

Recovering or disposal activities must be done by qualified personnel only outfitted with appropriate protective equipment (PPE) according to product size and device application life use. Waste generated by installation, maintenance or disposal process has to be managed according to National Standards/Regulations where product is installed.

Next general guidelines should be followed:

- Metal components (aluminium/steel) can be recovered/disposed as raw material.
- Sealing elements such as O-Ring or Gaskets (NBR, FPM, FVMQ...), as contaminated by fluids or lubricants, must be disposed of.
- Packaging materials should be transferred to separate waste collection system available in the Country.

16. DECLARATION OF CONFORMITY

ACTUATECH S.p.A. actuators have been designed, manufactured and tested to meet the requirements of the following European standards and are marked, where provided, with the relative CE conformity marking:

- 2006/42/EC Directive "Machinery";
- 2014/34/EU Directive "Equipment and protective systems intended for use in potentially explosive atmospheres" (ATEX);
- Regulation (EC) No 1907/2006 and successive concerning the Registration, Evaluation, Authorization and Restriction of Chemicals (REACH).

17. ENVIRONMENT IMPACT

ACTUATECH actuators and relevant production processes are designed to respect the environment and to prevent pollution:



machining, assembly, packaging and shipping processes are internal;



suppliers and subcontractors are close to our plant to reduce CO₂ emissions;



90% of components can be recovered or disposed as raw materials (see section 15);



actuators, correctly installed, do not need maintenance avoiding producing waste;



actuators packaging is completely recyclable.